



CRE-2100 Electra-Ride III™ Stairway Elevator **Technical Specifications**

Rev: 08-01-2008
ILS-00816

MODEL NUMBER: CRE-2100 & CRE-2100C
U.S. F.D.A. CLASSIFICATION: Class II,
CLASSIFICATION NUMBER: 890.5150

PERFORMANCE STANDARDS: USA Food & Drug Administration: None
ANSI/ASME: A18.1-2005 Safety Standard for Platform Lifts and Stairway Chairlifts
ANSI/ASME: A17.1-1996 Commercial (Part XX) &
Private Residence Inclined Lifts (PART XXI)
UL Listed: File Number SA11651

APPLICATIONS: Straight staircases, straight with top or bottom overruns and straight with intermediate landing. Variety of flat, spiral, and custom staircase configurations on both the inside and outside of the staircase.

RATED LOAD: 350 lbs.

NUMBER OF PASSENGERS: 1

POWER SOURCE: 24 Volt DC comprised of 2ea 7amp/hr 12 volt sealed maintenance-free lead acid batteries. On/Off power switch to prevent battery drain over lengthy storage periods.

CHARGER: 110 Volt AC 1.5 Amp, 24 Volt DC 3 Amp continuous monitoring, full primary cut off.

DRIVE: 24 Volt DC motor, 2 pole rated 1.02 hp intermittent duty (2hr cont.) limited at current setting, no load speed 3800 rpm.

GEAR BOX: 20:1 Right angle self locking worm drive.

INTERMEDIATE REDUCTION: (Motor & Gearbox) "J" style poly-V belt with dual 3 V wide belts, 4:1 reduction.

FINAL DRIVE: 8dp rack welded to inside of rail with a spur gear on the gearbox output shaft.

MOTOR CONTROLLER: C24 Volt DC pulse width modulated controller with acceleration ramping.

BRAKING: Dynamic motor braking through the motor controller and self locking worm gear box.

Bruno Independent Living Aids, Inc., 1780 Executive Drive, P.O. Box 84, Oconomowoc, WI 53066
Phone (800) 882-8183 Fax (262) 953-5501

Any reproduction or other use of these materials without written permission of Bruno Independent Living Aids, Inc. is expressly prohibited. Bruno Independent Living Aids, Inc. reserves the right to modify or make changes to these specifications at any time without notice.

REMOTE CONTROL: Custom 318 Mhz wireless "CALL/SEND" control with interference suppression. Momentary switching requires a user to continuously hold button to control unit. Optional "keyed" controls

STANDARD CONTROL: 3 position, momentary rocker switch requiring user to continuously hold rocker switch to control unit, switch mounted under armrest. Optional "keyed" control.

SUPPORTS: Clamps anchored to stair tread, normal rail position is 2" above step nose. Number and size of clamps dependent on the configuration and length of rail.

ANGLE: 0 to 45 degrees standard.

SPEED: User adjustable with a maximum of 28 feet per minute, actual loaded top speed 25 feet per minute.

LENGTH OF TRACK: Custom length rails to 50'.

TRACK CONSTRUCTION: 5/16" mild steel welded shape, covered gear rack welded to rail. Joint with welded on side clamp blocks at each rail joint.

TRACK LOCATION: Track is designed to the contour of the stairway and can fit to within 7"- 8" of the wall or obstruction.

TRACK EXTENSIONS: Standard track extension is 6" past the top step nose and 18-20" past the bottom step nose.

FOOTREST: Folding footrest with safety sensor panel and handle actuator.

SEAT: Padded, sliding park position, & self-locking swivel at both the top and bottom. Four position seat height adjustment.

SAFETY EQUIPMENT: 1) Seat swivel switch allows operation only when chair is center position.

- 2) Footrest safety switches
- 3) Retractable seat belts
- 4) Charging Light (amber) at each end of rail
- 5) 25 amp manual reset breaker on the motor control circuit
- 6) 5amp power switch fuse on the control circuits
- 7) Final end stop bumper at each end of the rail
- 8) Final limit switch
- 9) Full diagnostic interconnect circuit board
- 10) Optional overspeed safety brake

POWER OUTAGE: Unit will have 8 (minimum) to 20 round trips on battery charge (variance caused by angle, length of run, ambient temperature and rider weight). Batteries will last between 28 and 36 hours after the power is disconnected.

WEIGHT OF UNIT: 100 lbs. without rider typical carriage weight.
25 lbs. without rider typical seat weight.
16 lbs. per foot rail weight.

TESTING PERFORMED:

**Bruno Independent Living Aids, Inc., 1780 Executive Drive, P.O. Box 84, Oconomowoc, WI 53066
Phone (800) 882-8183 Fax (262) 953-5501**

Any reproduction or other use of these materials without written permission of Bruno Independent Living Aids, Inc. is expressly prohibited. Bruno Independent Living Aids, Inc. reserves the right to modify or make changes to these specifications at any time without notice.

- 1) Life cycle of 36,000+ cycles with full rated load at 45 degrees on a 20' rail. Gearbox, rail, and components had minimal wear. Estimated yearly heavy use is 1200 cycles. This test performed at manufacturer's location.
- 2) Battery charger meets UL 1236 battery charger specifications and has been independently tested.
- 3) The self locking gear box was statically tested with 2500 lbs (7X rated load) on a 45 degree rail for 15 minutes with no carriage movement. This test was performed at the manufacturer's location.
- 4) Repetitive tests were run to determine power outage cycling.
- 5) Electrical discharge to ground testing performed for FDA 510(k).

COMMERCIAL PACKAGE: Keyed rocker switch on chair, keyed remote call/send controls, and overspeed safety brake.

**Bruno Independent Living Aids, Inc., 1780 Executive Drive, P.O. Box 84, Oconomowoc, WI 53066
Phone (800) 882-8183 Fax (262) 953-5501**

Any reproduction or other use of these materials without written permission of Bruno Independent Living Aids, Inc. is expressly prohibited. Bruno Independent Living Aids, Inc. reserves the right to modify or make changes to these specifications at any time without notice.

CRE-2100 ELECTRA-RIDE™ III

TECHNICAL DATA/SPECIFICATIONS

- MODEL: CRE-2100 Electra-Ride III
 RATED LOAD: 350 LBS, ONE PASSENGER
 POWER SOURCE: 24 VOLT DC COMPRISED OF (2) 7 AMP/HR
 12 VOLT SEALED BATTERIES
 110 VOLT AC 1.5 AMP, 24 VOLT DC 3 AMP
 CONTINUOUS MONITORING CHARGER
 DRIVE: 24 VOLT DC MOTOR, 2 POLE RATED 1.02 HP
 NO LOAD SPEED OF 3800 RPM
 20:1 RIGHT ANGLE SELF LOCKING WORM DRIVE
 GEAR BOX WITH 4:1 INTERMEDIATE REDUCTION
 USING DUAL 3 V WIDE BELTS
 FINAL DRIVE: RACK & PINION - 8DP RACK WELDED TO THE
 RAIL WITH A SPUR GEAR ON THE GEARBOX
 SHAFT
 BRAKING: DYNAMIC MOTOR BRAKING THROUGH THE MOTOR
 CONTROLLER AND SELF LOCKING WORM GEAR
 CONTROLS: CONTINUOUS PRESSURE-ROCKER SWITCH LOCATED
 ON ARMREST AND WALL MOUNTED CALL/SEND
 CONTROLS LOCATED AT BOTH TOP & BOTTOM
 LANDINGS.
 ANGLES: 0 TO 45 DEGREES
 SPEED: 32 FEET PER MINUTE UNLOADED
 25 FEET PER MINUTE WITH RATED LOAD
 (SPEED SETTINGS ARE ADJUSTABLE)
 FINAL LIMIT SWITCH STANDARD
 ----- COMMERCIAL PACKAGE
 INCLUDES OVERSPEED BRAKE, KEYED CALL/SEND
 CONTROLS, & KEYED CONTROLS ON CHAIR.

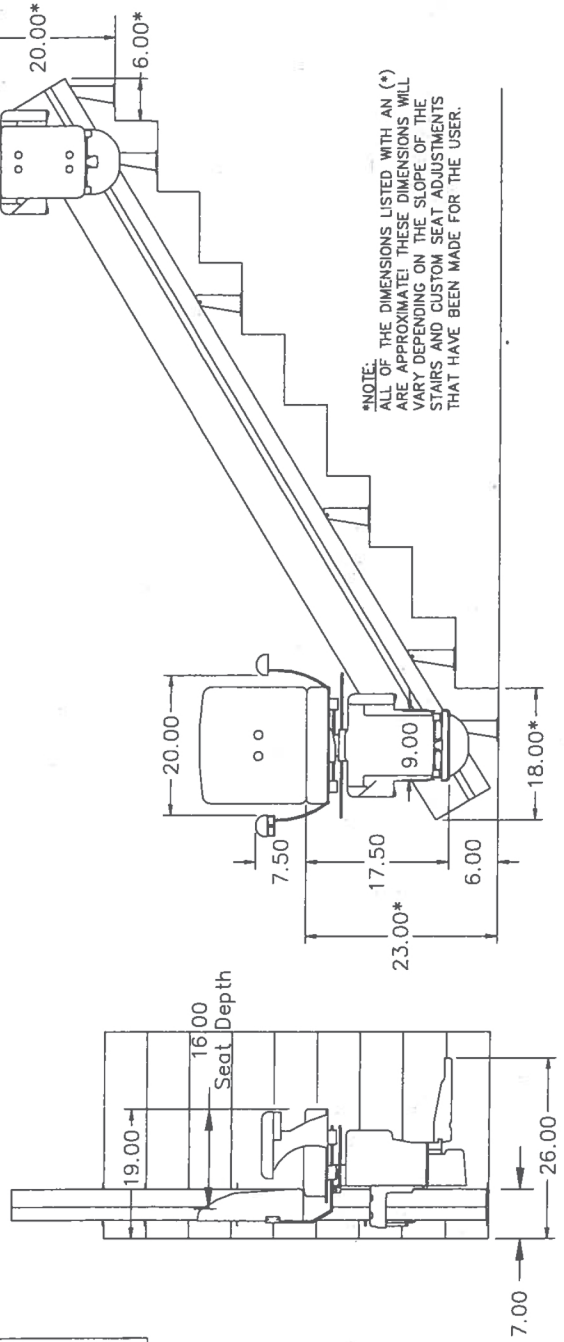
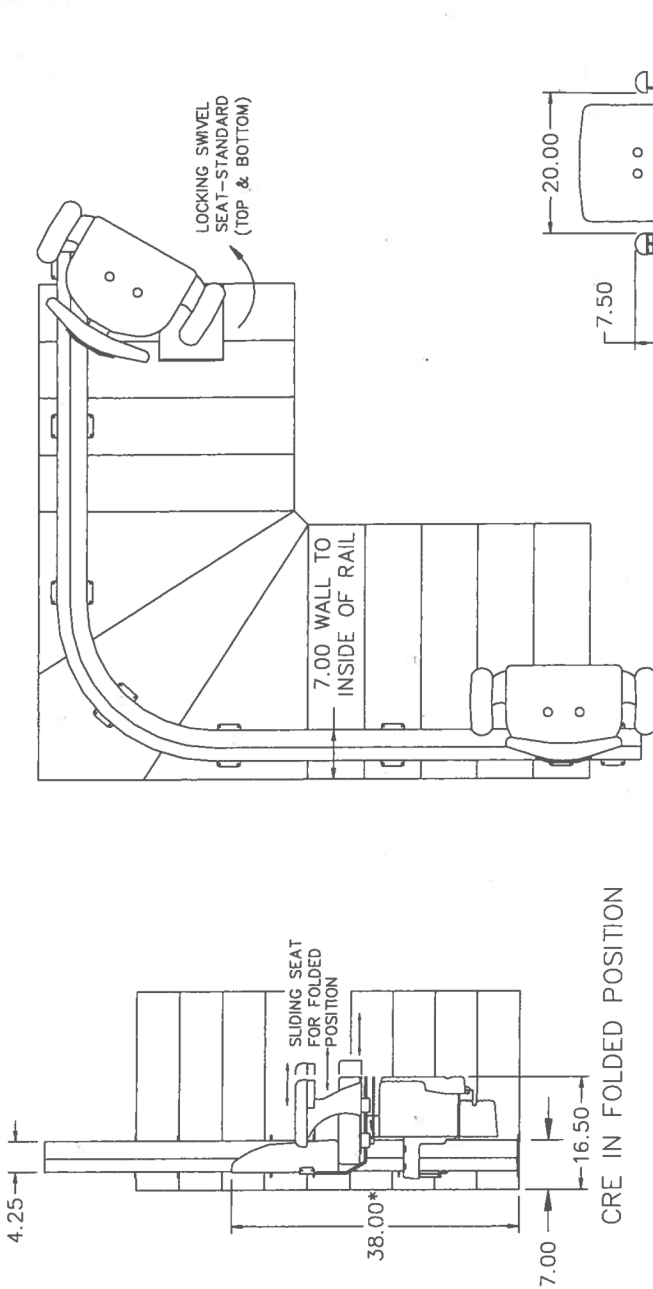

NOTE: ALL OF THE DIMENSIONS LISTED WITH AN () ARE APPROXIMATE! THESE DIMENSIONS WILL VARY DEPENDING ON THE SLOPE OF THE STAIRS AND CUSTOM SEAT ADJUSTMENTS THAT HAVE BEEN MADE FOR THE USER.



1780 Executive Drive
 P.O. Box 84
 Oconomowoc, WI 53066
 Tel 800-882-8183
 Fax 262-953-5501
<http://www.bruno.com/>

rev: 09/08/2003 ILS-00817

CRE-2100 ELECTRA-RIDE™ III

TECHNICAL DATA/SPECIFICATIONS

MODEL: CRE-2100 Electro-Ride III
RATED LOAD: 350 LBS, ONE PASSENGER
POWER SOURCE: 24 VOLT DC COMPRISED OF (2) 7 AMP/HR 12 VOLT SEALED BATTERIES
 110 VOLT AC 1.5 AMP, 24 VOLT DC 3 AMP CONTINUOUS MONITORING CHARGER
DRIVE: 24 VOLT DC MOTOR; 2 POLE RATED 1.02 HP
 NO LOAD SPEED OF 3800 RPM
 20:1 RIGHT ANGLE SELF LOCKING WORM DRIVE
 GEAR BOX WITH 4:1 INTERMEDIATE REDUCTION USING DUAL 3 V WIDE BELTS
FINAL DRIVE: RACK & PINION - 8DP RACK WELDED TO THE RAIL WITH A SPUR GEAR ON THE GEARBOX SHAFT
BRAKING: DYNAMIC MOTOR BRAKING THROUGH THE MOTOR CONTROLLER AND SELF LOCKING WORM GEAR
CONTROLS: CONTINUOUS PRESSURE ROCKER SWITCH LOCATED ON ARMREST AND WALL MOUNTED CALL/SEND CONTROLS LOCATED AT BOTH TOP & BOTTOM LANDINGS.
ANGLES: 0 TO 45 DEGREES
SPEED: 32 FEET PER MINUTE UNLOADED
 25 FEET PER MINUTE WITH RATED LOAD
 (SPEED SETTINGS ARE ADJUSTABLE)
FINAL LIMIT SWITCH STANDARD
 ----- COMMERCIAL PACKAGE
 INCLUDES OVERSPEED BRAKE, KEYED CALL/SEND CONTROLS, & KEYED CONTROLS ON CHAIR.

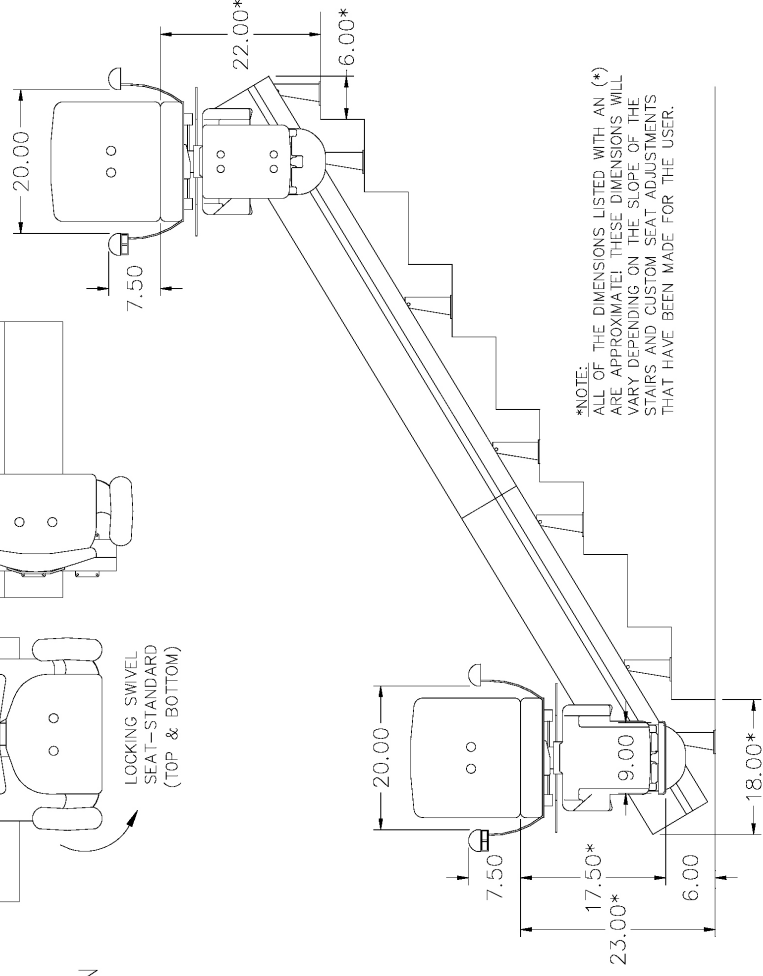
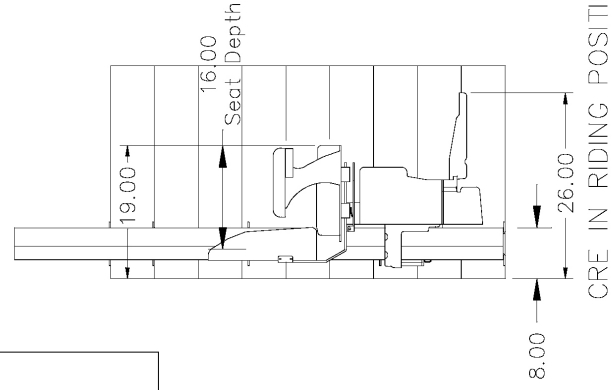
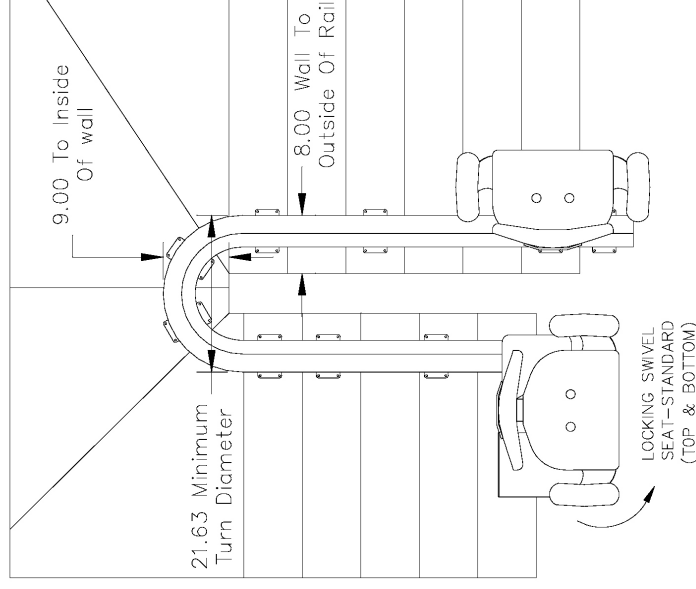
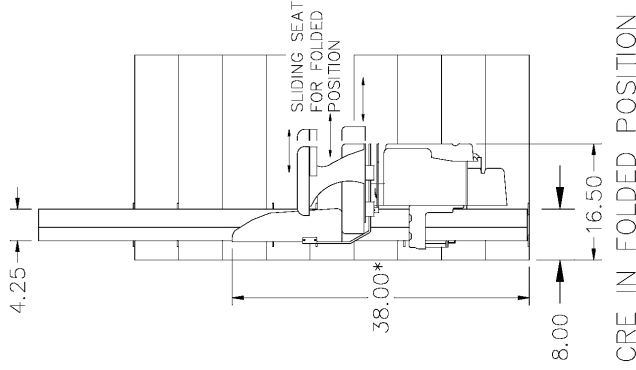

*NOTE:
 ALL OF THE DIMENSIONS LISTED WITH AN (*) ARE APPROXIMATE. THESE DIMENSIONS WILL VARY DEPENDING ON THE SLOPE OF THE STAIRS AND CUSTOM SEAT ADJUSTMENTS THAT HAVE BEEN MADE FOR THE USER.



1780 Executive Drive
 P.O. Box 84
 Oconomowoc, WI 53066
 Tel 800-882-8183
 Fax 262-953-5501
<http://www.bruno.com/>

rev: 09/08/2003 ILS-00817